

# Qubo Wall P/L

Assembly and operating instructions

**visplay**

play it smart

EN

These instructions facilitate the safe and effective use of the “Qubo Wall P/L” product.

These instructions are part of the product and must be kept safely and in easy reach from the product at all times.

All persons who use or handle this product must have read these instructions. Observance of all the safety and handling instructions given in these instructions are a prerequisite for safe working.

The figures in these instructions serve for general understanding and may differ from the actual version.

All dimensions in these instructions are given in mm.

### Quality assurance

All processes in our company are subject to a comprehensive management system, which conforms to the quality standard ISO 9001 and the environmental standard ISO 14001.

The management system is regularly inspected by the Zertifizierungs- und Umweltgutachter GmbH (BSI), which documents conformance to the standards by a certificate.

### Copyright

These instructions are protected by copyright. Their use is permitted within the scope of use of the product. Any use over and above this is only permitted with the written approval of the manufacturer.

Our General Terms and Conditions of Sale and Supply are valid for all orders.

## Table of Contents

<b>1 Safety .....</b>	<b>3</b>
1.1 Explanation of symbols .....	3
1.2 Intended use .....	3
1.3 Fundamental dangers .....	3
<b>2 Product description .....</b>	<b>3</b>
2.1 Overview.....	3
2.2 Brief description.....	3
2.3 Power supply.....	3
2.4 Scope of supply and accessories.....	4
<b>3 Assembly.....</b>	<b>5</b>
3.1 Unpacking .....	5
3.2 Storage .....	5
3.3 Requirements of installation location.....	5
3.4 Mounting wall frame .....	6
3.5 Back bar for shelf.....	7
3.6 Tray for cables and converters.....	7
3.7 Slip-on shelf brackets .....	7
3.8 Visplay plug system.....	8
<b>4 Operation.....</b>	<b>9</b>
4.1 Cleaning.....	9
<b>5 Dismantling and disposal.....</b>	<b>9</b>
5.1 Dismantling .....	9
5.2 Disposal.....	9
<b>6 Technical data .....</b>	<b>9</b>
6.1 Dimensions .....	9
6.2 Connection values .....	9
6.3 Load values.....	9

# 1 Safety

## 1.1 Explanation of symbols

Safety instructions are marked as follows in these instructions.

**⚠ WARNING**

A safety instruction marked in this manner indicates a possible dangerous situation, which if not prevented may result in death or severe injury.

**⚠ NOTE**

A safety instruction marked in this manner indicates a possible dangerous situation, which if not prevented may result in damage to property and the environment.

## 1.2 Intended use

The product is used exclusively for incorporating merchandise supports for the presentation of goods.

Merchandise supports and electrical devices permitted are exclusively those that conform to the specification in these instructions.

### Field of application

The product must be used exclusively in the commercial field.

### Personnel

These instructions describe the assembly of the product as well as its handling and cleaning. Therefore these instructions must be handed on to the end user after successful assembly of the product.

The contents of the section on "Assembly" is directed at personnel who undertake the assembly and the electrical connection (e.g. shop fitters, licensed electricians).

The contents of the section on "Handling" is directed at the end users (e.g. sales personnel, visual merchandisers).

**⚠ WARNING**

**In the event of misuse, there is the danger that the merchandise supports and the electrical devices will be damaged. This may lead to injury and damage to the product.**

- > Use only approved accessories and electrical devices.
- > Comply with the permitted connection, maximum load and equipment values.
- > Do not lean any ladders against the merchandise supports.

## 1.3 Fundamental dangers

**⚠ WARNING**

- > Do not load the merchandise supports above the maximum load capacity.
- > Do not place any receptacles, from which fluids can escape, on the merchandise supports.
- > Keep moisture away from current conducting components.

# 2 Product description

## 2.1 Overview

The Qubo Wall P/L is a structural shelving system, with a high degree of design freedom, for wall structures.

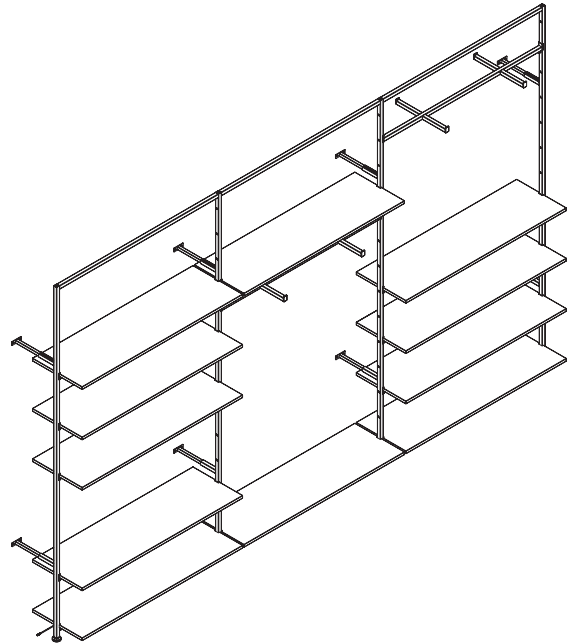

Fig. 1: Qubo Wall P/L

## 2.2 Brief description

Qubo Wall P/L is a steel upright, with or without power tracks for electrified shelves with LED lighting, with a 175 mm hole matrix. This allows the use of shelves with integrated light fittings for additional illumination of the goods on display.

The wall system can be configured by fitting connecting tubes.

## 2.3 Power supply

The 24 V distributor enables power supply to a maximum of 8 connections, each with a maximum of 2 converters of 75 W. The switched input enables the use of a switch.

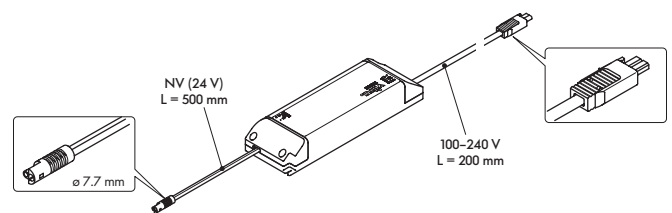

Fig. 2: Converter

**NOTE! It is imperative to take account of power consumption of the electrical devices. The dimmer set 318-271.19 is required for the use of dimmers.**

For an overview of the electrical connection of the wall uprights and the associated components see the section on Electrification 3.8.

## 2.4 Scope of supply and accessories

### 2.4.1 Wall uprights

Steel uprights with or without integrated power tracks for supplying electricity to shelves with LEDs. The spigots are for fitting connecting tubes. The wall uprights are available in the following versions:

- Upright outside left electrified or non-electrified (A)
- Centre upright electrified or non-electrified (B)
- Upright outside right non-electrified (C)

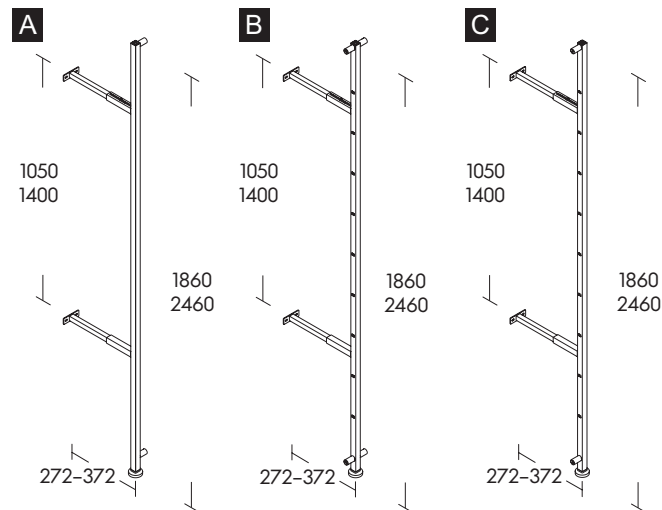

Fig. 3: Wall uprights

### 2.4.2 Connecting tube set

The connecting tubes are screwed on to the spigots on the upright. Please use the assembly key (111-844.12).

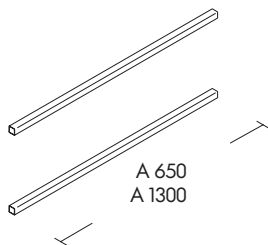

Fig. 4: Connecting tube

### 2.4.3 Back bar for shelf without electrification

The back bars serve to support glass and wooden shelves. The back bar, including the two shelf supports, are hung between the wall uprights.

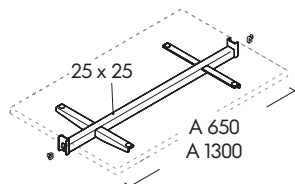

Fig. 5: Back bar for shelf without electrification

### 2.4.4 Back bar for shelf with electrification

The back bars serve to support glass and wooden shelves. The back bars are hung between the wall uprights using shelf supports. The shelf support set consists of

two supports, whereby one of them is for power take-up (Fig. 6/1). A LED luminaire (Fig. 6/2) is built into the electrified back bar. The power take-up is at the left side.

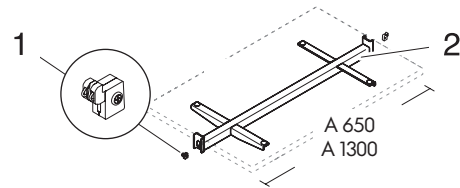

Fig. 6: Back bar for shelf with electrification

### 2.4.5 Hanging rail

The hanging rails, including the two shelf supports, are hung between the wall uprights

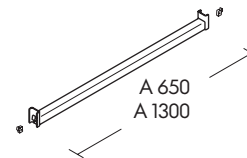

Fig. 7: Hanging rail

### 2.4.6 Hanging rail with front arms

The hanging rails, including the two shelf supports, are hung between the wall uprights.

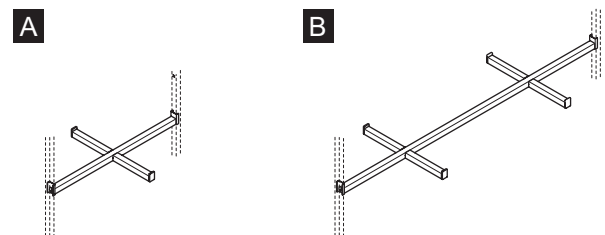

Fig. 8: Hanging rail with front arms

The hanging rails are available in the following versions:

- Hanging rail with a front arm on each side for axis 650 mm (A)
- Hanging rail with two front arms on each side for axis 1300 mm (B)

### 2.4.7 Slip-on shelf brackets

The slip-on shelf brackets are inserted over the connection tube.

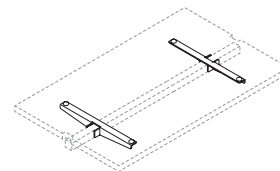

Fig. 9: Slip-on shelf brackets

### 2.4.8 LED spotlight

The LED spotlight is inserted into the perforated holes on the powered wall upright.

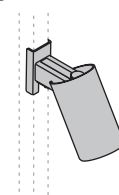

Fig. 10: LED spotlight

## 3 Assembly

### ⚠ WARNING

The system can fail if the assembly is not carried out correctly or the base cannot support the necessary load. There is a danger of injury from goods or merchandise supports falling down.

- > Note and comply with all the following instructions on assembly.
- > Make sure that the fixings and base can support a pulling force of 0.1 kN per fixing point.

### 3.1 Unpacking

Immediately on receipt, check the delivery is complete and intact.

If transport damage is noted, proceed as follows:

- Do not accept delivery or only under reservation.
- Make a note of the extent of the damage on the transport documents or the delivery note of the transport company.
- Initiate a complaint.

### Packaging

The product is securely packed so that transport damage is unlikely.

- Store original packaging for subsequent transport.
- Only send product in original packaging.
- Take note of all instructions which are given on the packaging.

### Disposing of packaging materials

If the packaging materials are no longer required, dispose of them according to local disposal regulations.

### 3.2 Storage

Store the product and its components under the following conditions:

- Do not store outdoors.
- Store in a dry and dust-free place.
- Do not expose to any aggressive media.
- Protect from direct sunlight.
- Avoid mechanical shocks.
- Storage temperature: 23 °C
- Relative humidity: 50%

### 3.3 Requirements of installation location

The installation location must comply with the following requirements:

- The installation location must be dry. Construction outdoors is not permitted.
- The ceiling must be designed for, and able to support, the load to be borne (check with architect and structural engineer).

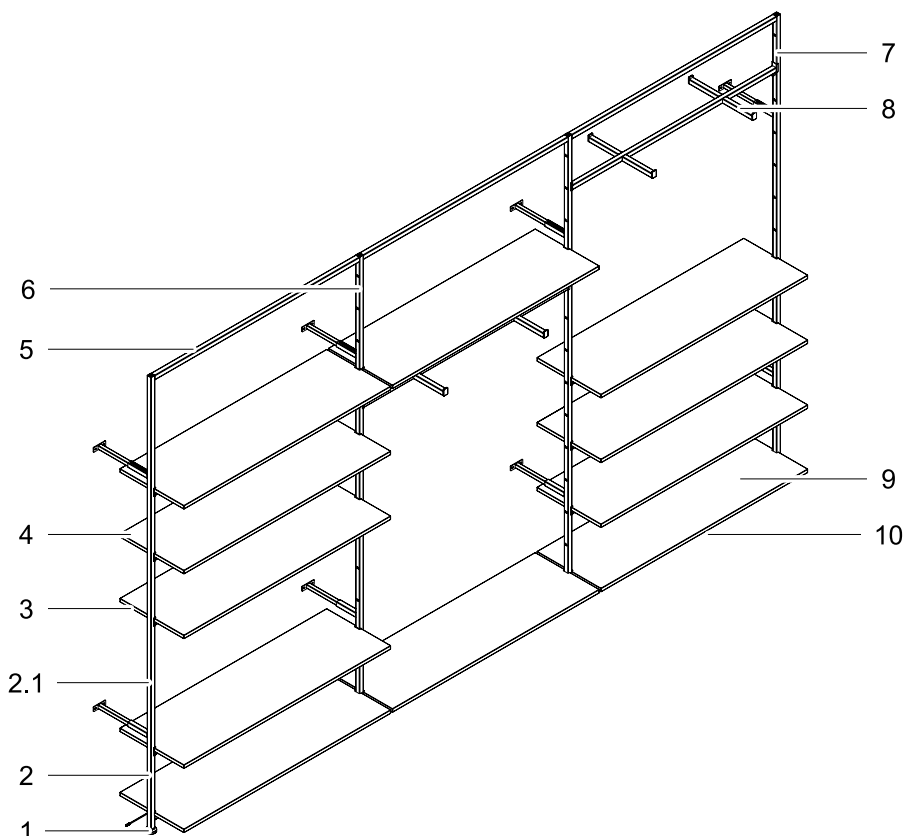

1	Glide, height-adjustable
2	Outer wall upright, left
2.1	Integrated power track
3	Back bar for shelf
4	Wooden/glass shelf
5	Connecting tube (top, bottom)
6	Wall upright, centre
7	Outer wall upright, right
8	Hanging rail with front arms
9	Slip-on shelf brackets
10	Tray for cables and converters

EN

## 3.4 Mounting wall frame

### 3.4.1 Connecting uprights with connecting tubes

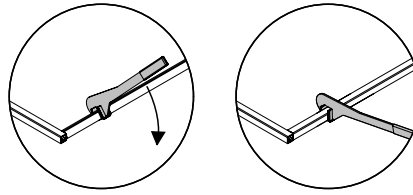
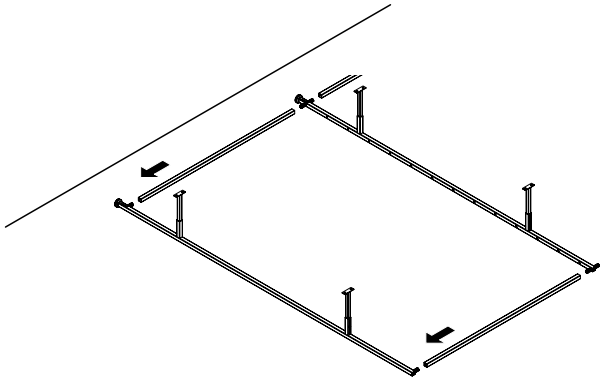

**ATTENTION!** The connecting tubes must be twisted with the assembly tool and positioned properly.

### 3.4.2 Align on the wall

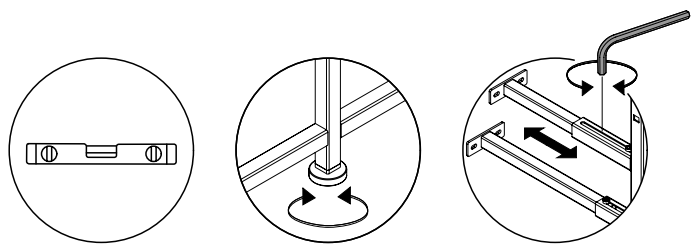
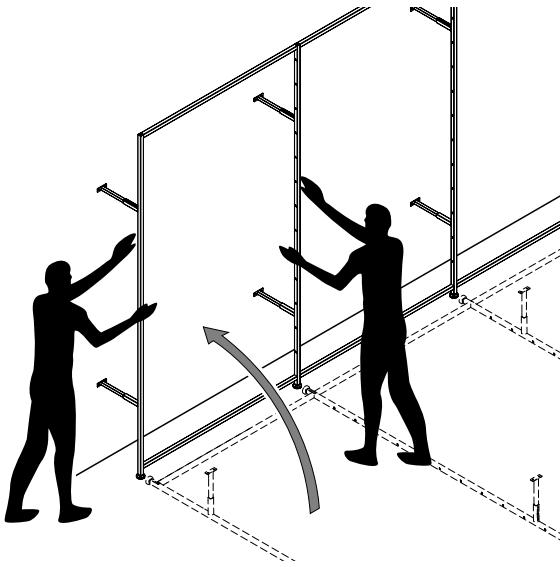

### 3.4.3 Wall fixing

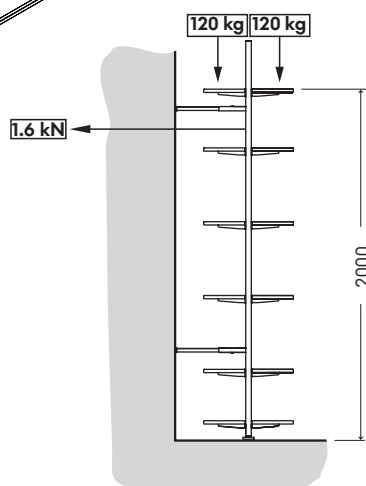
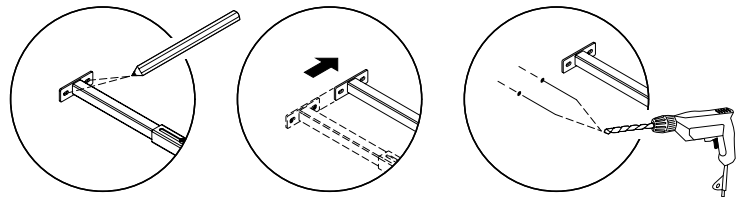
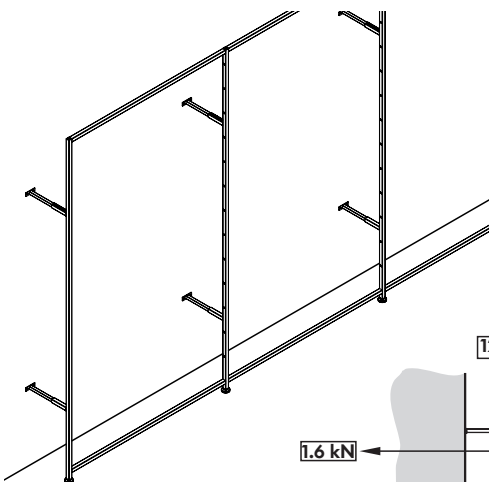

#### **⚠ NOTE**

Please observe the information on the loading values and ensure that the substructure of the wall installation and its fastenings can cope with the expected loads.

- > The permissible weight load of all accessories: max. 240 kg.  
The weight load must be reduced as the height of the accessories increases.
- > The correct size and type of anchor fixings must be used to suit the construction conditions.
- > Check anchor fixing as specified by manufacturer.
- > All mounting points must be used.

## 3.5 Back bar for shelf

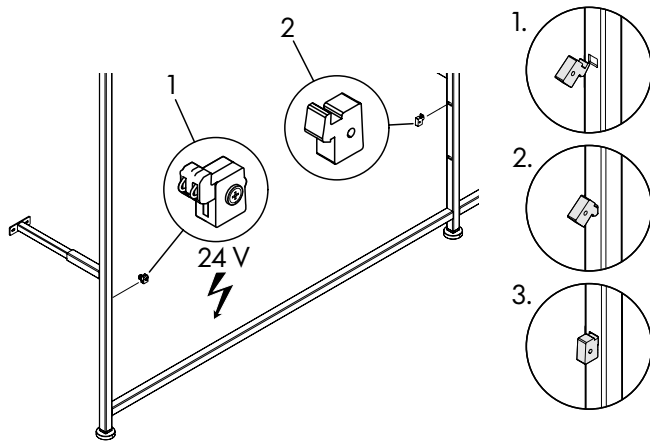

**ATTENTION!** With electrified versions, attention must be given to the position of the electrified shelf support (1) on the shelf frame, by default always left-sided.

Construction drawings are available to download in the product section at [www.visplay.com](http://www.visplay.com), or can be requested if needed.

Drawing number:

994-015 wooden shelf 640 mm

994-016 wooden shelf 1290 mm

994-017 glass shelf 640 mm

994-018 glass shelf 1290 mm

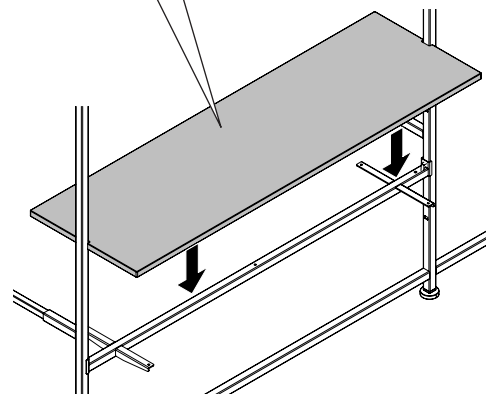
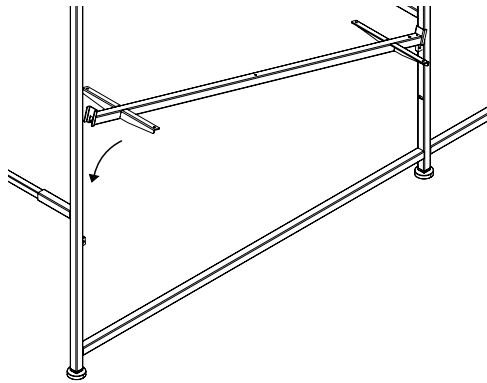

## 3.6 Tray for cables and converters

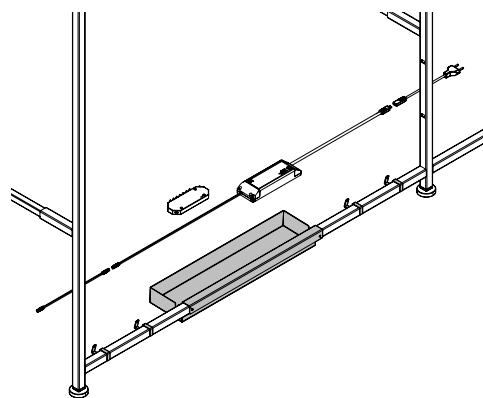
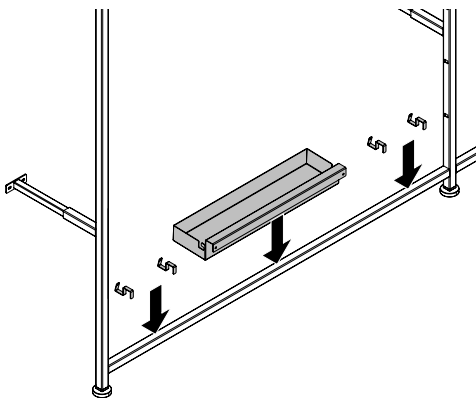

## 3.7 Slip-on shelf brackets

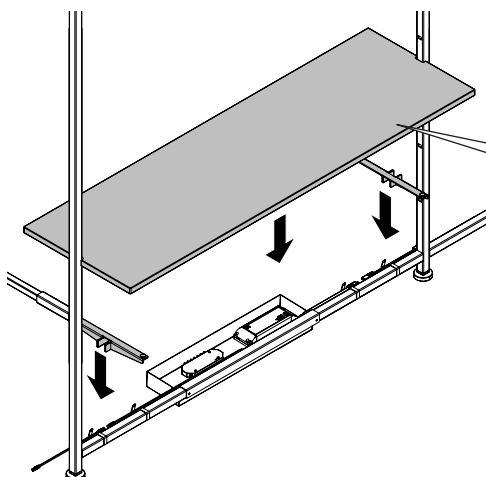

Construction drawings are available to download in the product section at [www.visplay.com](http://www.visplay.com), or can be requested if needed.

Drawing number:

994-015 wooden shelf 640 mm

994-016 wooden shelf 1290 mm

## EN 3.8 Visplay plug system

### ⚠ NOTE

It is imperative to take account of power consumption of the electrical devices!

The maximum power consumption should be 10% below the nominal output rating of the converter.

### Operation with 75 W converter

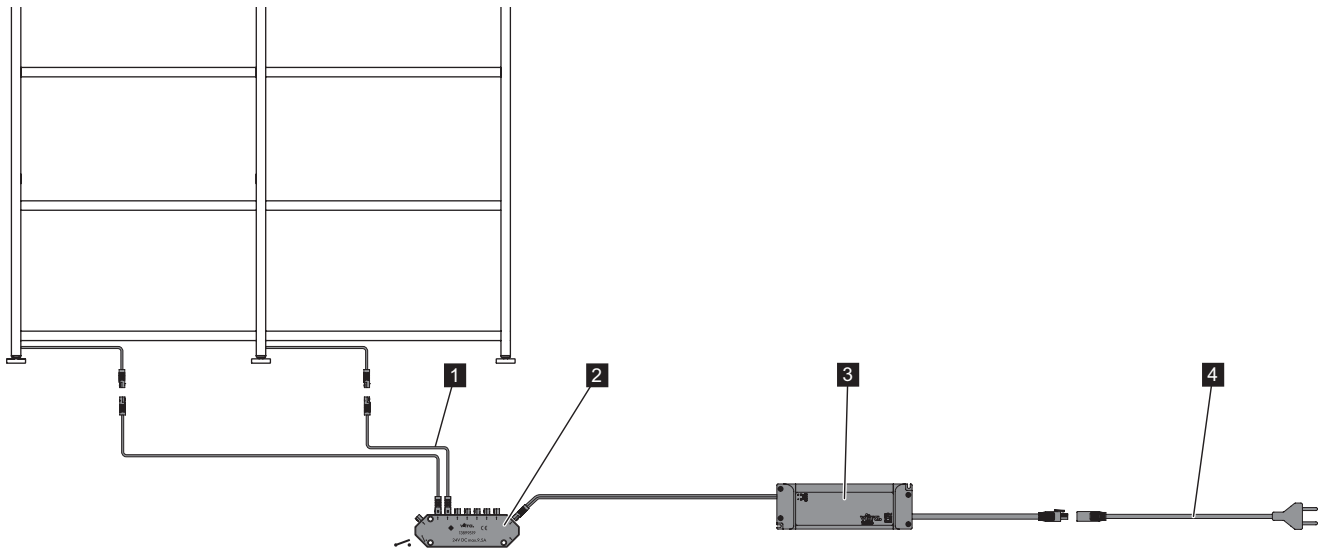

### Operation with 150 W converter

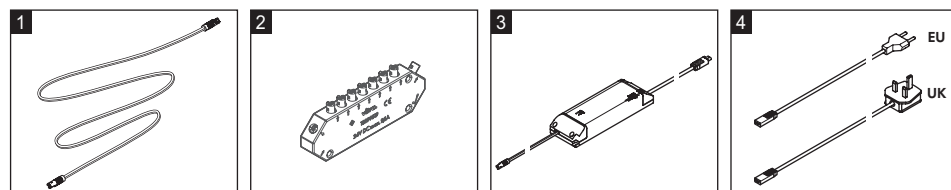
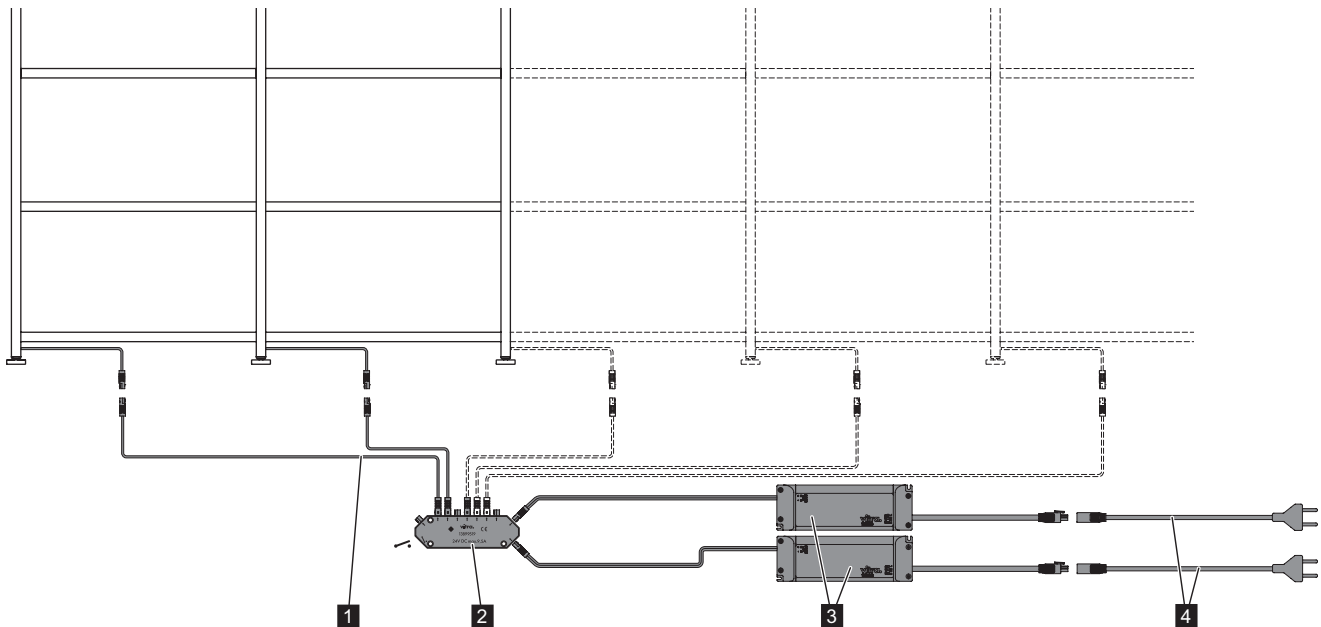

- 1 Extension cable 24 V
- 2 24 V distributor, 8-way
- 3 75 W LED converter
- 4 Supply lead 220 – 240 V



## 4 Operation

### ⚠ WARNING

Injury can be caused and the merchandise supports and/or system can be damaged if the maximum load of the merchandise supports is exceeded.

- > Observe the maximum load values of the individual merchandise supports.
- > Do not exceed the maximum load of 120 kg per upright.

### 4.1 Cleaning

During the course of time, dust and deposits from clothes hangers can settle on the merchandise supports. In order that the goods on display do not become soiled, the merchandise supports must be regularly cleaned.

Remove goods from the merchandise support.

1. Remove dirt on the merchandise support carefully with a soft, dry cloth.
2. Remove stubborn dirt with a mild cleaning agent.

## 5 Dismantling and disposal

### 5.1 Dismantling

- > Pull out the plug from the electric socket.
- > Dismantle converters and power distributors (where present).

### 5.2 Disposal

#### ⚠ NOTE

If product components are improperly disposed of they can pose a danger to the environment.

- > Ensure product components are disposed of in a proper environmental manner or through waste management specialists.
- > Send components that can be recycled for recycling.
  - Send metal components for recycling or scrapping.
  - Send plastics for recycling.
  - Have electrical and electronic components disposed of by an approved waste management specialist.
  - Dispose of remaining components sorted according to the type of material.

## 6 Technical data

### 6.1 Dimensions

Converter dimensions, dependent on power output

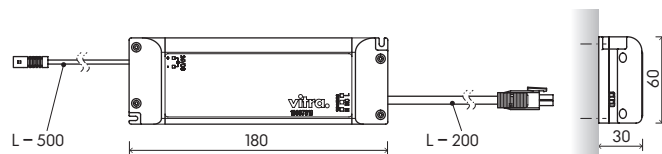

Fig. 11: Converter dimensions

### 6.2 Connection values

#### General

Specification	Value	Unit
Operating voltage	100-240	V
Frequency	50-60	Hz
Nominal voltage (SELV)	24	V
Maximum load	9.5 225	A W
Mains protection class; converter 10-150 W	II	
Maximum casing temperature (converter)	90	°

### 6.3 Load values

The maximum load applies including the dead weight and the weight of all components

#### Wall upright

Specification	Load
Maximum load	120 kg

#### Shelf

Specification	Load
Maximum load	40 kg

#### Support bar

Specification	Load
Maximum load	40 kg

#### Hanging rail with front arms

Specification	Load
Maximum load	40 kg

